

This manual is for reference and historical purposes, all rights reserved.

**This page is copyright© by M. Butkus, NJ.**

This page may not be sold or distributed without the expressed permission of the producer

I have no connection with any camera company

On-line camera manual library

This is the full text and images from the manual. This may take 3 full minutes for the PDF file to download.

**If you find this manual useful, how about a donation of \$3 to: M. Butkus, 29 Lake Ave., High Bridge, NJ 08829-1701 and send your e-mail address so I can thank you. Most other places would charge you \$7.50 for a electronic copy or \$18.00 for a hard to read Xerox copy.**

**This will allow me to continue to buy new manuals and pay their shipping costs.**

**It'll make you feel better, won't it?**

**If you use Pay Pal or wish to use your credit card,  
click on the secure site on my main page.**

**Canon**

SURE SHOT  
*85zoom*

SURE SHOT  
*85zoom*  
*Date*

**E**

**F**

**S**

**P**

**PRIMA**  
**ZOOM 85**

**PRIMA**  
**ZOOM 85**  
**DATE**



**E** English

**F** Français

**S** Español

**P** Português

## Handling Precautions

1. This camera is not resistant to water, and should not be used outdoors if it is raining or snowing. If it is accidentally dropped in water, contact an authorized Canon service facility. Keep the camera out of salt spray and excessive humidity. If used at the beach, clean it thoroughly afterward with a dry cloth.
2. Store the camera in a cool, dry, dust-free place. Be sure to keep the camera out of direct sunlight, and away from "hot spots" such as the trunk or rear window shelf of a car. Avoid places where mothballs are used, and use a desiccant in excessive humidity.
3. Do not attempt to disassemble the camera yourself, since there is high-voltage circuitry inside.
4. The batteries may explode or cause burns if disassembled, recharged, shorted, exposed to high temperatures, or disposed of in a fire.
5. Use a blower brush to remove dust and sand from the lens and inside the camera. Do not apply any fluids to the lens or body. Take the camera to an authorized Canon service facility for a more thorough cleaning if necessary.
6. Film passing through X-ray examinations at an airport may be exposed and ruined even when loaded in the camera. Request a different method of inspection to avoid damage.
7. Color reproduction may be adversely affected if the film is left in the camera for a long time. Always develop exposed film promptly.

This device complies with Part 15 of the FCC Rules. Operation is subject to the following two conditions: (1) This device may not cause harmful interference, and (2) this device must accept any interference received, including interference that may cause undesired operation.

Do not make any changes or modifications to the equipment unless otherwise specified in the instructions. If such changes or modifications should be made, you could be required to stop operation of the equipment.

This equipment has been tested and found to comply with the limits for a class B digital device, pursuant to part 15 of the FCC Rules. These limits are designed to provide reasonable protection against harmful interference in a residential installation. This equipment generates, uses and can radiate radio frequency energy and, if not installed and used in accordance with the instructions, may cause harmful interference to radio communications.

However, there is no guarantee that interference will not occur in a particular installation. If this equipment does cause harmful interference to radio or television reception, which can be determined by turning the equipment off and on, the user is encouraged to try to correct the interference by one or more of the following measures:

- Reorient or relocate the receiving antenna.
- Increase the separation between the equipment and receiver.
- Consult the dealer or an experienced radio/TV technician for help.

---

This digital apparatus does not exceed the Class B limits for radio noise emissions from digital apparatus as set out in the interference-causing equipment standard entitled "Digital Apparatus", ICES-003 of the Industry Canada.

---

Cet appareil numérique respecte les limites de bruits radioélectriques applicables aux appareils numériques de Classe B prescrites dans la norme sur le matériel brouilleur: "Appareils Numériques", NMB-003 édictée par l'Industrie Canada.

---

 The CE Mark is a Directive conformity mark of the European Community (EC)

## Thank you for purchasing this Canon product.

Before taking pictures, please read these instructions carefully for a thorough understanding of how the camera works.

## Table of Contents

These instructions are divided into four sections: Introduction, Basic Operations, Advanced Operations, and Additional Information. When first using the camera, be sure to read the instructions starting from the Introduction.

### Conventions

The following conventions are used in these instructions:



Warnings you should observe when using the camera.



Additional information on using the camera.



Tips on taking photographs with the camera.

## 1

### Introduction

Handling Precautions	2
Table of Contents	4
Quick Reference	6
Nomenclature	8
Attaching the Strap	10





## 2

### Basic Operations

Becoming Familiar with Your Camera	11
1 Loading the Battery	11
2 Turning the Power On and Off	12
Checking the Battery Power	13
3 Viewfinder	14
4 Changing the Subject Size	15
5 Shutter Button Action	16
Holding the Camera	17
Loading the Film	18
Taking Pictures (Full Auto Mode)	20
Green/Orange Indicators	22
Removing the Film	23

### 3

## Advanced Operations

Focus Lock (Focusing near the edge of the picture frame) . . . . .	24
AiAF (Smart AF) Function . . . . .	25
Imprinting the Date/Time <b>DATE</b> . . . . .	26
Setting and Adjusting the Date/Time <b>DATE</b> . . . . .	27
Changing the Shooting Mode . . . . .	28
1 <b>AUTO</b> Auto Flash Mode without Red-eye Reduction . . . . .	29
2  <b>AUTO</b> Auto Flash Mode with Red-eye Reduction . . . . .	30
Red-eye Reduction Function . . . . .	31
3  Flash ON Mode . . . . .	32
4  Flash OFF Mode . . . . .	33
5 <b>RT</b> Real Time Release Mode . . . . .	34
6  Self-timer Mode . . . . .	36
Slow-synchro Function . . . . .	37

**E**

### 4

## Additional Information

Troubleshooting . . . . .	38
Questions and Answers . . . . .	39
Specifications . . . . .	40

1

2

3

4

Please note that these instructions are for both the model with the date function and the model without the date function. Information relevant only to the model with the date function is marked with the **DATE** symbol.

## Quick Reference

For further details, refer to the page indicated by (→ ■).

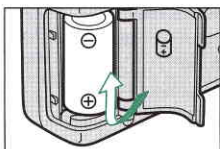

1. Load the battery. (→ 11)

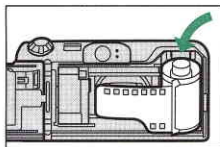

2. Load the film. (→ 18)

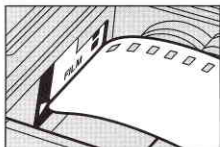

3. Pull the film tip across until it reaches the  mark. Then close the back cover. (→ 18)

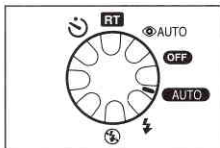

4. Turn the mode dial to **AUTO**. (→ 12)  
→ The power is turned on and the lens is set.

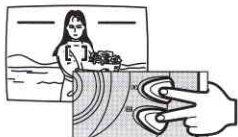

5. Change the subject size as desired. (→ 15)

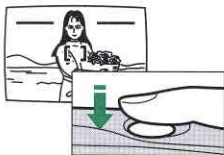

6. Position the AF frame over the subject and lightly press the shutter button halfway down. (→ 16)

- Keep the shutter button pressed halfway down.
- Check that the green indicator is lit and then compose the picture.



7. Press the shutter button fully. (→ 16)

- In low light, the flash fires automatically.

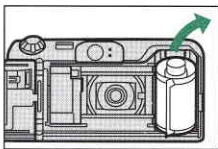

8. When the film has finished and rewound, remove the film. (→ 23)



## Nomenclature

\* (→ ■) is shorthand for "See page ■".

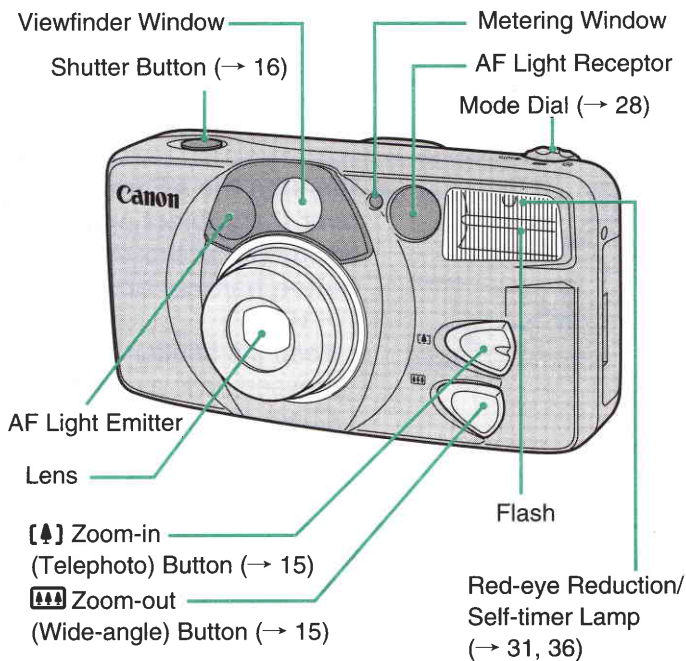

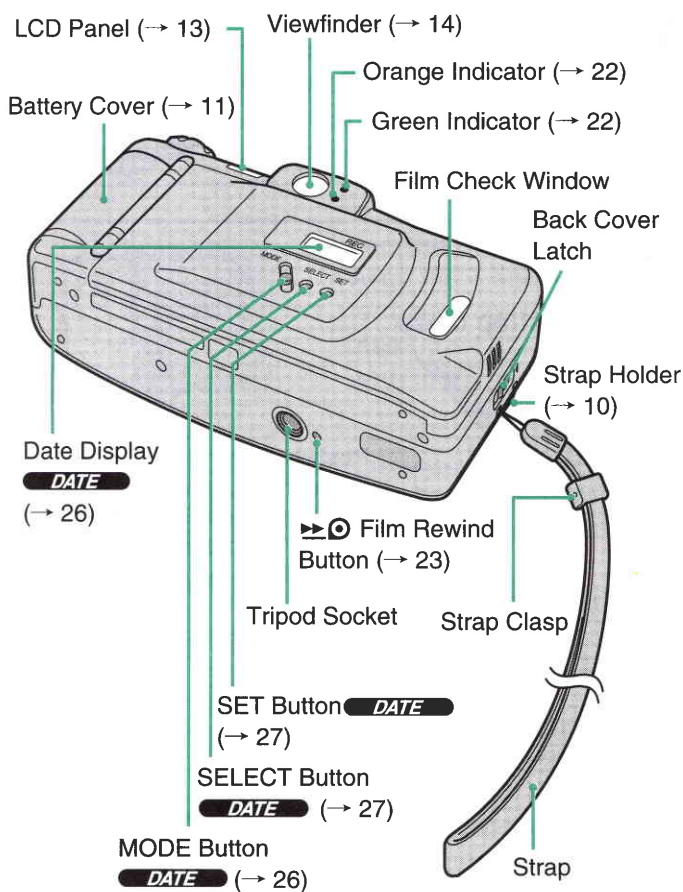

## Attaching the Strap

Before using your camera, attach the strap provided. Be careful not to drop the Camera.

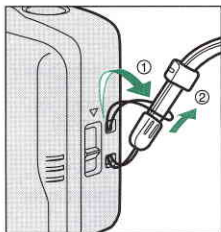

**Pass the strap through the strap holder on the side of the camera.**

- Follow step ① before step ②.

### Button on strap clasp

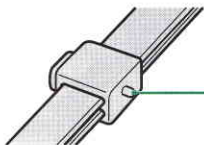

#### Push-button release

- Use this button to press the SELECT and SET buttons (→ 27) and the  button (→ 23).

## Becoming Familiar with Your Camera

### 1 Loading the Battery

Battery : One lithium battery (DL123A or CR123A, 3V)

E

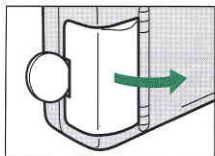

#### 1. Open the battery cover.

- To open, insert a coin into the slot.

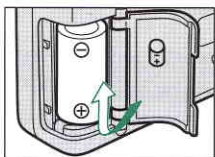

#### 2. Load the battery.

- Align the + and - terminals correctly and insert the battery top (- end) first.

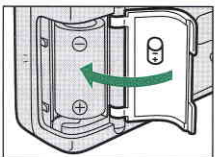

#### 3. Close the battery cover.

- Close the cover until it clicks.
- ➔ is displayed on the LCD panel.
- ➔ The date display is reset to "94. 1. 1.". Readjust to the correct date/time. (→ 27)

1

2

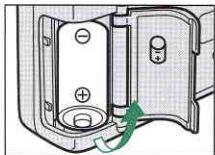

When removing the old battery, pull the bottom (+ end) out first.

### 2 Turning the Power On and Off

When a mode is selected with the mode dial, the power is turned on and pictures can be taken.

#### Turning the Power On

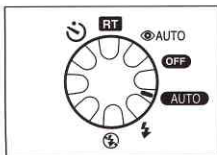

Turn the mode dial to any mode (except **OFF**).

➔ The lens is set for shooting.



• Do not touch the lens.



- The lens first zooms to the full wide (38mm) position.
- If the lens is not set for shooting, check to see if the battery is loaded correctly.

#### Turning the Power Off

To protect the lens, be sure to turn off the camera.

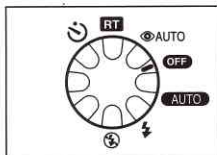

Turn the mode dial to **OFF**.



➔ The lens retracts into the camera.

## Checking the Battery Power

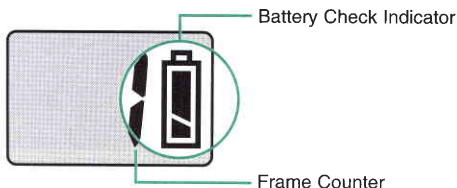
You can check the battery power level with the indicator on the LCD panel.



### Battery Check Indicator

-  Battery in good condition
-  Prepare a new battery
-  Replace the battery (→ 11)

### Shooting capacity

Approx. 17 rolls of 24-exposure film, at normal temperatures with 50% flash use. (Data based on Canon's Standard Test Method.)



- Before shooting, be sure to check the battery power.
- When traveling or planning to take many pictures, be sure to take a supply of spare batteries; they may not be available where you are.
- The shooting capacity is reduced by about 1/3 if the camera is used at low temperatures.

### 3 Viewfinder

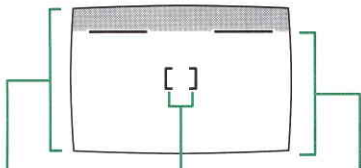
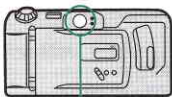

#### **Picture frame**

For ordinary shooting, compose your picture within this frame.

#### **Close-up frame**

When the shooting distance is between 0.6 and 1 m (2 and 3.3 ft.), compose your picture within this frame. The area above this frame will not be included in the picture.

#### **AF frame**

Place this frame over the subject you wish to focus on.

#### 4 Changing the Subject Size

You can freely change the size of the image with the zoom buttons.



**[W]** Wide-angle (38mm)



**[T]** Telephoto (85mm)

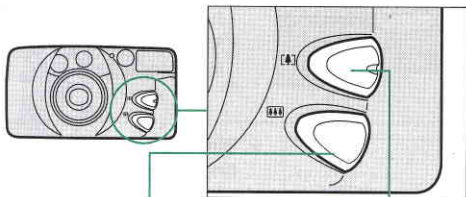

#### **[W]** Zoom-out (Wide-angle)

Press for a wide area image. For taking landscapes, group pictures, etc.

#### **[T]** Zoom-in (Telephoto)

Press to zoom in on your subject. For taking portraits, etc.



- If the lens remains extended for approx. 4 minutes without use, the lens automatically retracts into the camera and is set to the wide-angle (38mm) position. This prevents damage to the lens.



### 5 Shutter Button Action

This camera has a two-step shutter button.

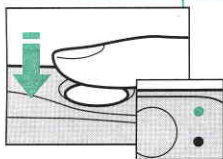
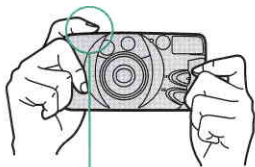

#### 1. Press the shutter button halfway to focus.

- Keep the shutter button halfway pressed.
- Make sure the green indicator is lit.

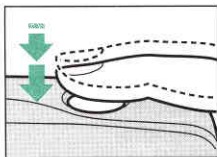

#### 2. Without releasing your finger, press the shutter button fully to take the picture.

- ➔ The shutter is released.
- Be sure to press the shutter button gently.



- There is a very short interval between the shutter button being pressed and the shutter operating. As a general guide, it is best to hold the camera still until you hear the film start to wind forward.
- In Auto mode  **AUTO**, the shutter operates about 1 second after the red-eye reduction lamp lights.

## Holding the Camera

To take sharp pictures, hold the camera firmly so that it does not move.

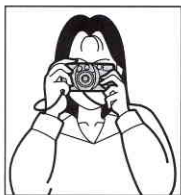

- Hold the camera with both hands.
- Keep your elbows close to your body.
- Hold the camera against your nose and look through the viewfinder.

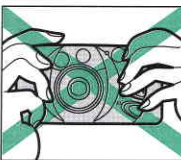
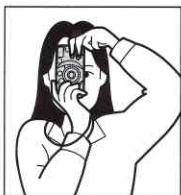

- Be careful to keep fingers and hair from obstructing the lens, AF light emitter and receptor, metering window, and flash.

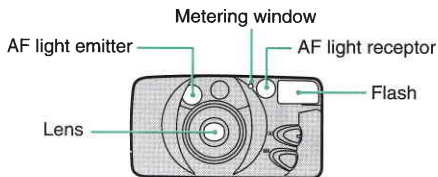

## Loading the Film

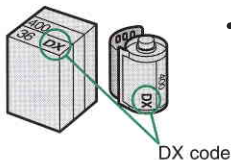

- Use DX-coded 35mm film.

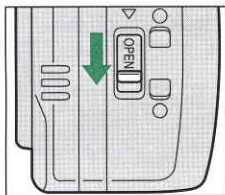

1. Slide the back cover latch downwards.  
➔ The back cover opens.

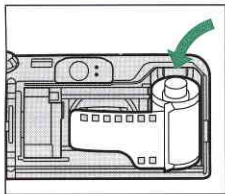

2. Insert the film.

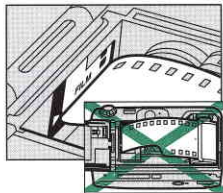

3. Pull the film tip across until it reaches the  mark.
  - Make sure the film lies flat.

## 4. Close the back cover.

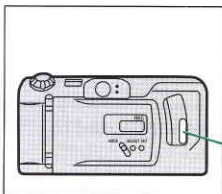

You can check if a film is loaded by looking here.

## 5. "1" is displayed in the frame counter.

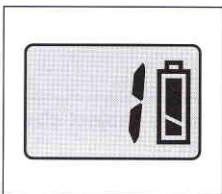

- If "0" blinks in the frame counter, the film has not loaded properly. Reload the film.
- If the camera malfunctions while a film is loaded, do not remove the film. Take the camera to a Canon service facility with the film still inside.
  - If you force the film out of the camera, the camera or film may be damaged.



- We recommend you use ISO 400 film.

## Taking Pictures (Full Auto Mode)

Even if the subject is not exactly centered, the AiAF (Smart AF) function will focus on the subject. In low light conditions, the flash will fire automatically. (→ 29)

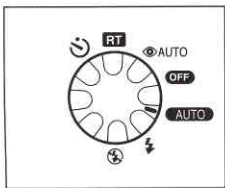

### 1. Turn the mode dial to **AUTO**.

- ➔ The power is turned on, and the lens is set for shooting.

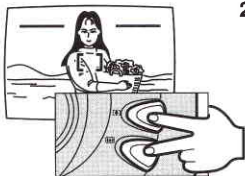

### 2. Change the subject size as desired.

- Look through the viewfinder and press the zoom button to achieve the desired picture composition.

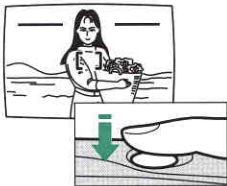

### 3. Position the AF frame over the subject and press the shutter button halfway.

- Keep the shutter button halfway pressed.
- Make sure the green indicator is lit.
- Compose the picture.

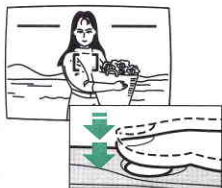

**4. Press the shutter button fully.**

- In low light conditions, the flash fires automatically.

**E**

**2**

### Green/Orange Indicators

When the shutter button is pressed halfway, the indicators light up or blink to indicate whether or not shooting is possible.

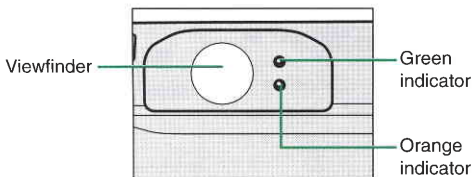

#### ① Green indicator

Lights up: Subject is in focus. (Ready for shooting.)

Blinks: Subject is too close (close-range warning).

Release the shutter button and move away from the subject slightly, then press the shutter button halfway again and check if the green indicator blinks. Repeat this step until the green indicator does not blink.

#### ② Orange indicator

Lights up: Flash lamp is charged.

Blinks: Camera shake warning (in "Flash OFF" mode).

We recommend you use a tripod.

## Removing the Film

The film rewinds automatically when it reaches the end.



The frame counter counts down during film rewinding. Once rewinding is complete, "0" is displayed in the frame counter and the film can be removed.

E

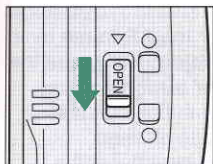

**1. Slide the back cover latch downwards.**

➔ The back cover opens.

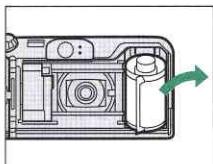



**2. Remove the film.**

2

### Rewinding the film in mid-roll

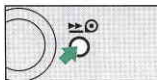
- Press the  button on the bottom of the camera.
- Use the push-button release on the strap.



- Before opening the back cover to remove the film, be sure to check that "0" is displayed in the frame counter. If "0" is not displayed, press the  button to complete rewinding.
- Exposures taken after those indicated on the film roll may be cut off.



## Focus Lock

Use this mode to focus on a subject positioned close to the edge of the picture frame.

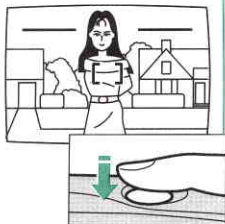
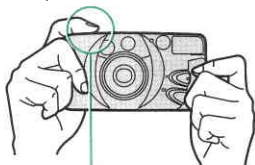

**1. Center the AF frame over the subject and press the shutter button halfway.**

- Keep the shutter button halfway pressed.
- Make sure the green indicator is lit.

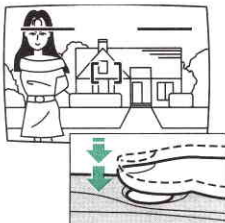

**2. With the shutter button halfway pressed, frame your picture as desired. Then press the shutter button fully.**



- Once you have focused on the subject, be careful not to change the distance between the subject and the camera. If the distance does change, repeat steps 1 and 2.

## AiAF (Smart AF) Function

Ai = Artificial intelligence, AF = Auto-focus

The AiAF (Smart AF) function has a wide measuring area and is the latest mechanism for providing accurate focus adjustment. This mechanism was developed based on the analysis of several thousand photographs and on Canon's unique know-how.



- The camera focuses on the subject even if it is not in the center of the viewfinder, or if there is an obstruction in front of it.

The camera will accurately focus on two subjects positioned side by side, and not on the background between them.

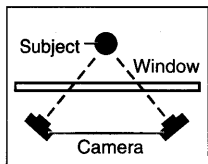

- If you are taking a picture through a window, set the camera at an appropriate angle, with a camera-to-window distance of about 20 cm/0.7 ft.

If you are too far away from the window, the camera may focus on the glass of the window rather than the subject.

## Imprinting the Date and Time **DATE**

The automatic built-in calendar is programmed until the year 2019 and allows you to record the date and time on the bottom right-hand corner of the photograph. It is not necessary to set the date every time you shoot.

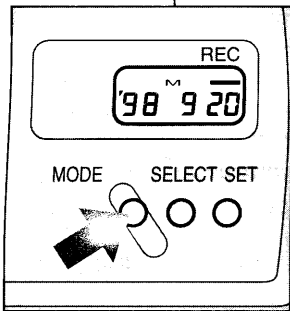
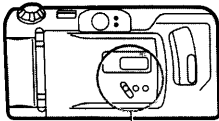

**Press the MODE button.**

➔ The display changes every time you press.

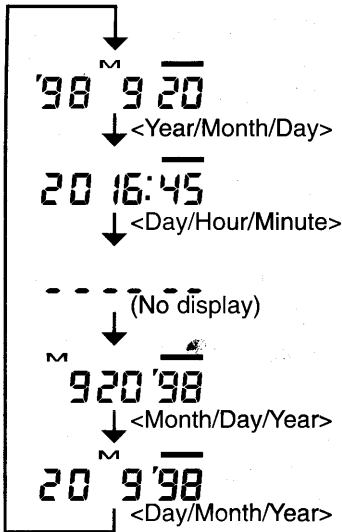

Month indicator

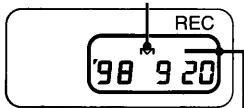

Imprinting confirmation indicator

- Select one of the above formats, then take the picture.



- The imprinting confirmation indicator flashes when the shutter operates to notify you that the date is being imprinted on the photograph.

## Setting and Adjusting the Date/Time

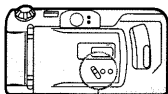

Be sure to reset the display when you replace the battery (the date reverts to "94 1 1") or when you are travelling to a different time zone.

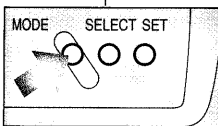

### 1. Press the **MODE** button.

- Display the date/time format to be corrected.

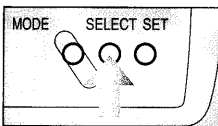

### 2. Press the **SELECT** button.

- Press until the digit to be corrected blinks.

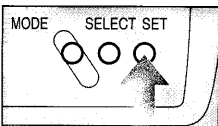

### 3. Press the **SET** button.

- Change the digit to the one desired.

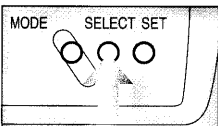

### 4. Press the **SELECT** button until all digits stop blinking.

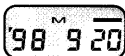

3



- Use the push-button release on the strap.
- Each time the SET button is pressed, the number increases by one. If kept pressed, the number increases quickly.

## Changing the Shooting Mode

The flash can be forced to fire or can be turned off. Choose the mode suitable for the subject or place you are shooting.

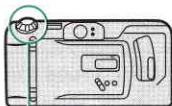

Turn the mode dial to select the mode.

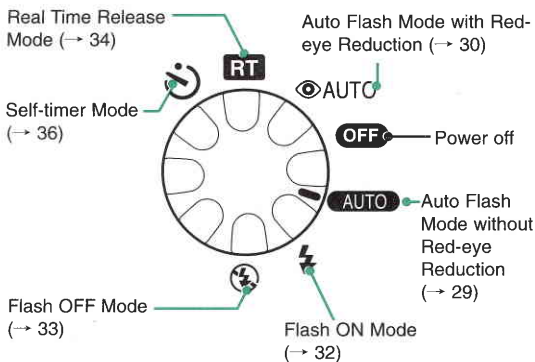

## 1 **AUTO** Auto Flash Mode without Red-eye Reduction

In low light conditions, the flash fires automatically without the red-eye reduction function.

Use this mode for taking pictures without people, or if you want to shoot right away.

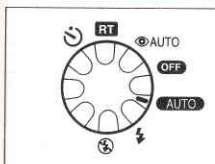

Turn the mode dial to **AUTO**.

3

### Flash Distance Range (With color print film)

Film speed	38mm (Wide-angle)	85mm (Telephoto)
ISO 100	0.6 to 5.3 m (2 to 17.4 ft.)	0.6 to 2.5 m (2 to 8.2 ft.)
ISO 400	0.6 to 10.6 m (2 to 34.8 ft.)	0.6 to 5 m (2 to 16.4 ft.)

## Changing the Shooting Mode

### 2 AUTO Auto Flash Mode with Red-eye Reduction

Use this mode to reduce the red-eye effect that can occur when you take pictures of people with the flash lamp. In dark conditions, the red-eye reduction lamp automatically lights before the flash fires.

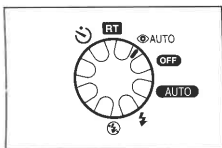

1. Turn the mode dial to  AUTO .

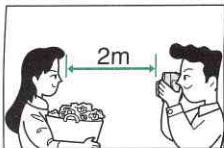

2. Stay within about 2 m/  
6.6 ft. of your subject.
  - The red-eye reduction lamp is only effective within this distance.

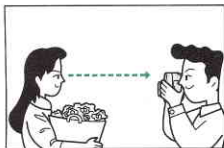

3. Tell your subject to look at the camera.
  - The red-eye reduction function is not effective unless the subject looks straight at the lamp.

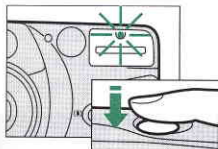

#### 4. Press the shutter button halfway.

- ➔ The red-eye reduction lamp lights up and the shutter will not release for about one second.
- Keep the shutter button halfway pressed.

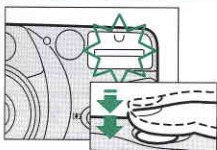

#### 5. After about one second, press the shutter button fully.

- ➔ The flash fires and the shutter is released.

### Red-eye Reduction Function

With flash photography in dark places, the subject's eyes may appear red. This phenomenon is called "red-eye" and occurs when flash illumination reflects off the retina.

In red-eye reduction mode  **AUTO**, the red-eye reduction lamp lights for about 1 second before the flash is fired. This causes the pupils of the subject's eyes to contract and minimizes the likelihood of red-eye occurring.

The efficacy of the red-eye reduction function varies from person to person.



- When the red-eye reduction lamp is lit, shutter release is delayed by about 1 second to increase the effectiveness of the red-eye reduction function. For immediate shutter release, select **AUTO**,  or **RT** on the mode dial before shooting.



- The effectiveness of red-eye reduction can be enhanced by making the room as bright as possible and by using a wide-angle lens setting.



## Changing the Shooting Mode

### 3 ⚡ Flash ON Mode

The flash fires regardless of the light conditions. Use this mode for fill-in flash during the day, or to soften the outline of the subject.

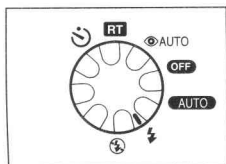
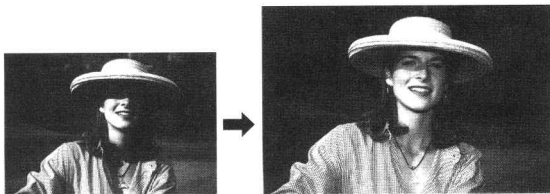

Turn the mode dial to ⚡.

#### 4 Flash OFF Mode

The flash will not fire even in low light conditions. Use this mode where flash photography is prohibited, for night views, or for available-light photography.

**E**

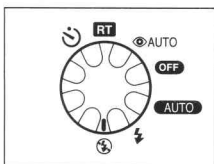
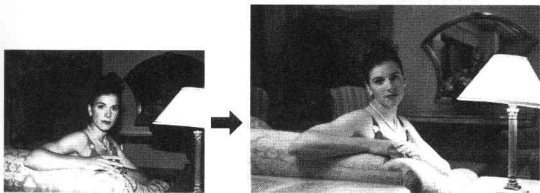

Turn the mode dial to  .

**3**



- A slower shutter speed (max. approx. 2 sec.) is set when taking pictures in low light; be sure to hold the camera steady.
- If the orange indicator blinks to indicate camera shake, place the camera on a steady surface or mount it on a tripod.

## Changing the Shooting Mode

### 5 **RT** Real Time Release Mode

In normal photography, after you check that the green indicator is lit and press the shutter button, there is a very short interval before the picture is actually taken. With real time release, the photograph is taken almost instantly (within 0.03 seconds).

Use this mode for situations such as photographs of rapid movement or children's faces where an instant camera response is essential.

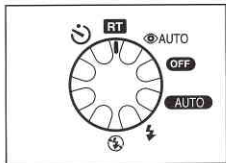

#### 1. Turn the mode dial to

**RT** .

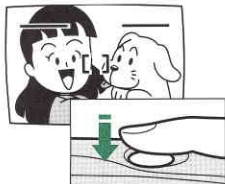

#### 2. Position the AF frame over the subject and hold the shutter button down halfway.

- The camera makes a brief zooming sound.
- Make sure the green indicator is lit.
- Photographs using focus lock can be taken in the same way as in normal photography. (→ 24)

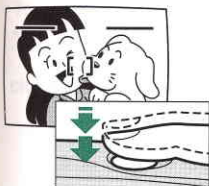

- 3. Keep the camera aimed at the subject. When you see the picture you want, press the shutter button fully.**

**E**



- If you press the shutter button right away, real time release will not work.
- Once you have focused on the subject, be careful not to change the distance between the subject and the camera. If the distance does change, repeat steps 1 and 2.



- Because auto-focusing is automatically set to one point in the center of the viewfinder, position the AF frame over the subject.
- The flash mode for real time release is auto flash mode without red-eye reduction.

**3**

## Changing the Shooting Mode

### 6 Self-timer Mode

Include yourself in the picture by delaying shutter release with the self-timer.

In bright conditions, the self-timer operates in the auto flash mode with red-eye reduction. In low light conditions it automatically operates with the slow-synchro function (→ 37). Place the camera on a steady surface, or mount it on a tripod.

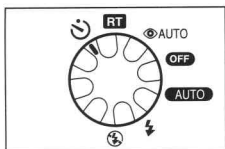

1. Turn the mode dial to  .



2. Position the AF frame over the subject and press the shutter button.

- ➔ The self-timer lamp blinks (approx. once/sec.) for about 10 seconds before the shutter is released. The number of seconds remaining is displayed on the LCD panel.



- Do not stand in front of the camera when pressing the shutter button. This will cause incorrect focus.



- The lamp blinks more rapidly approximately two seconds before the shutter is released. However, if the red-eye reduction function has been activated, the lamp will remain lit during the last two seconds before the shutter is released.
- Photographs using focus lock can be taken in the same way as in normal photography. (→ 24)

## To cancel the self-timer mode

- Turn the mode dial to another mode.

**E**

### Slow-synchro Function

The slow-synchro function is effective when taking pictures of people in evening or night views when the background is dark. The slower shutter speed allows distant backgrounds not illuminated by the flash to be included in the photograph.

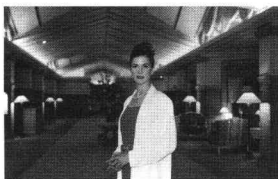

The self-timer operates automatically with the slow-synchro function in low light conditions.

**3**

- A slower shutter speed (max. approx. 1/2 sec.) is set in this mode. Also, tell your subject to keep still for a moment after the flash has fired.

# Troubleshooting

In case of trouble, check the table below before taking your camera to be repaired.

Problem	Cause	Remedy	Page
The battery check indicator  blinks.	<ul style="list-style-type: none"> <li>The battery has expired.</li> </ul>	<ul style="list-style-type: none"> <li>Replace the battery.</li> </ul>	11
The battery check indicator  is not displayed.	<ul style="list-style-type: none"> <li>No battery is loaded.</li> </ul>	<ul style="list-style-type: none"> <li>Load the battery.</li> </ul>	11
	<ul style="list-style-type: none"> <li>The battery is inserted with the wrong polarity.</li> </ul>	<ul style="list-style-type: none"> <li>Reinsert the battery correctly.</li> </ul>	11
	<ul style="list-style-type: none"> <li>The battery has completely expired.</li> </ul>	<ul style="list-style-type: none"> <li>Replace the battery.</li> </ul>	11
The shutter does not release.	<ul style="list-style-type: none"> <li>The mode dial is set to <b>OFF</b>.</li> </ul>	<ul style="list-style-type: none"> <li>Select a mode with the mode dial, suitable for the subject or place you are shooting.</li> </ul>	12, 28
	<ul style="list-style-type: none"> <li>The battery has expired.</li> </ul>	<ul style="list-style-type: none"> <li>Replace the battery.</li> </ul>	11
	<ul style="list-style-type: none"> <li>The film is not loaded properly.</li> </ul>	<ul style="list-style-type: none"> <li>Reload the film correctly.</li> </ul>	18
	<ul style="list-style-type: none"> <li>A rewind film is loaded in the camera.</li> </ul>	<ul style="list-style-type: none"> <li>Remove the film and load a new one.</li> </ul>	23, 18
	<ul style="list-style-type: none"> <li>The shutter will be released only after red-eye reduction lamp is lit for about 1 second.</li> </ul>	<ul style="list-style-type: none"> <li>Keep pressed until the shutter is released.</li> <li>Change the flash mode.</li> </ul>	31 28
The photographs are blurred.	<ul style="list-style-type: none"> <li>When the shutter was released, the AF light emitter and receptor were blocked.</li> </ul>	<ul style="list-style-type: none"> <li>Ensure that the AF light emitter and receptor are not blocked by hair, fingers, etc.</li> </ul>	17
	<ul style="list-style-type: none"> <li>In self-timer mode, you stood immediately in front of the camera when pressing the shutter button.</li> </ul>	<ul style="list-style-type: none"> <li>Make sure you do not stand immediately in front of the camera when pressing the shutter button.</li> </ul>	36
	<ul style="list-style-type: none"> <li>The camera moved when the shutter button was pressed (camera shake).</li> </ul>	<ul style="list-style-type: none"> <li>Press the shutter button gently.</li> </ul>	16

Problem	Cause	Remedy	Page
"H" blinks on the LCD panel.	<ul style="list-style-type: none"> <li>An error occurred during automatic winding.</li> </ul>	<ul style="list-style-type: none"> <li>Turn the power on. If the H is still displayed, replace the battery.</li> </ul>	12

## Questions and Answers

**Q.1** Can slide film be used with this camera?

**A.1** Yes it can, but use DX-coded 35mm film with a speed of ISO 25, 50, 100, 200, 400, 800 or 1600.

**Q.2** What is ISO?

**A.2** The ISO number indicates the film's sensitivity to light in numerical terms. The higher the number, the more sensitive the film is to light. For ordinary photography ISO 400 film is recommended.

**Q.3** Can films other than DX-coded 35mm films be used?

**A.3** Yes they can, but non-DX-coded films are automatically registered as ISO 25. For ISO 25 films and non-DX-coded film, load the film and close the back cover. Press the shutter button once or twice.

**Q.4** The date imprinted on the photograph is difficult to read.

**A.4** Is this because the background of the date imprint is bright? Frame the photograph so that the date is set against something dark, or at least so that it is not set against anything white or yellow.



## Specifications

**Type:** 35mm fully automatic lens-shutter camera with built-in zoom

**Image Size:** 24 × 36 mm

**Lens:** Canon 38mm–85mm f/4.2–8.7

**Focus Control:** Ai active auto-focus system

**Shooting Distance:** 0.6 m (2 ft.) to infinity

**Shutter:** Electromagnetic drive shutter with combinable programs

**Viewfinder:** Real-image zoom viewfinder

**Viewfinder Displays:** Picture frame, close-up frame, AF frame

**Viewfinder Eyepiece Area:** Green indicator (ready for shooting/close-range warning), Orange indicator (camera shake warning/flash charged)

**Film Loading:** Automatic (automatic blank film advance)

**Film Winding:** Automatic

**Film Rewinding:** Automatic at end of film, mid-roll rewinding possible

**Frame Counter:** Counts up during winding, counts down during rewinding

**Film Loaded Verification:** Film window on back cover

**Self-timer:** Electronically-controlled 10-second delay timer, activated by pressing the shutter button. The self-timer lamp blinks and the frame counter counts down the remaining seconds.

### **Metering Range (ISO 100):**

Auto/Flash ON modes

Wide: 1/36 f/4.2 to 1/500 f/16 (approx. EV9.3 to EV17)

Tele: 1/83 f/8.7 to 1/500 f/34 (approx. EV12.6 to EV19.2)

Flash OFF mode

Wide: 2 sec. f/4.2 to 1/500 f/16 (approx. EV3.1 to EV17)

Tele: 2 sec. f/8.7 to 1/500 f/34 (approx. EV5.2 to EV19.2)

Self-timer mode (Auto + Slow-synchro)

Wide: 1/2 f/4.2 to 1/500 f/16 (less than EV9.3; slow-synchro, EV9.3 to EV17 ; using AE)

Tele: 1/2 f/8.7 to 1/500 f/34 (less than EV12.6; slow-synchro, EV12.6 to EV19.2 ; using AE)

**Film Speed Setting:** ISO 25 to 3200; DX-coded film set in one-step increments

**Built-in Flash:** Built-in retractable flash, automatically fires in low light conditions.

## Flash Range:

- ISO 100 Wide: 0.6 to 5.3 m (2 to 17.4 ft.)  
Tele: 0.6 to 2.5 m (2 to 8.2 ft.)
- ISO 400 Wide: 0.6 to 10.6 m (2 to 34.8 ft.)  
Tele: 0.6 to 5 m (2 to 16.4 ft.)

**Flash Recycling Time:** Approx. 5 seconds (using a new battery)

**Flash Mode Selection:** Dial operated

- ① Auto mode without red-eye reduction:  
Automatically fires in low light conditions
- ② Auto mode with red-eye reduction:  
Automatically fires in low light conditions
- ③ Flash ON mode: Always fires
- ④ Flash OFF mode: No flash
- ⑤ Self-timer mode: Automatically fires in low light conditions (with slow-synchro)
- ⑥ Real-time release mode: Automatically fires in low light conditions, no red-eye reduction, single-point center focusing, release time lag of 0.03 sec.

**Power Supply:** One lithium battery (DL123A or CR123A, 3V)

**Shooting Capacity:** Approx. 17 rolls of 24-exp. film, at normal temperatures with 50% flash use.

**Dimensions (W × H × D):**

Model without date: 123 × 64 × 41.8 mm (4.8 × 2.5 × 1.6 in)

Model with date: 123 × 64 × 46 mm (4.8 × 2.5 × 1.8 in)

**Weight (without camera battery):**

Model without date: 215 g (7.6 oz.)

Model with date: 225 g (7.9 oz.)

## DATE

**Type:** Built-in LCD panel and automatic calendar with quartz digital date/time clock, programmed with dates until the year 2019 (compensates automatically for long and short months and leap years)

**Data Types:** 4 date/time formats

**Character Display Format:** 7-segment LCD

**Date/Time Color:** Orange

**Date/Time Power Supply:** Same as camera supply

- All data are based on Canon's Standard Test Method.
- Subject to change without notice